

# PRODUCT INFO SHEET

Nanmac Corporation

Quality • Performance • Solutions

## Head Mount Transmitter Standard F11-40 Series

The F11-40 series is a basic, non-isolated, easy-to-use two-wire transmitter for in-head mounting in DIN B and similar heads. Reduced height simplifies mounting in low profile connection heads. Needing no external power supply other than your LOOP power, the F11-40 can be used for three or four wire RTDs; as well as, thermocouple calibration types B, C (W5), E, J, K, N, R, S & T.

Thermocouple input cold junction compensation (CJC) is fully automatic by means of an accurate measurement of the terminal temperature. Alternatively, the CJC can be disabled upon request. Also available are head mount enclosures with digital displays. Either regular duty or heavy duty, NEMA rated head mount displays.

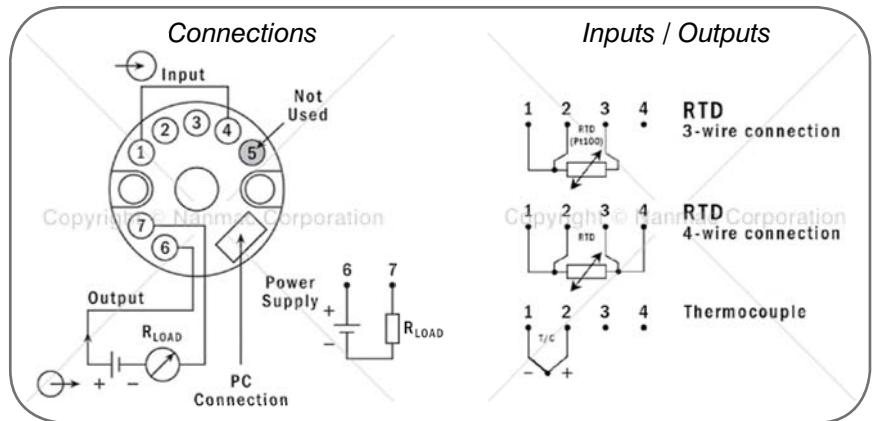
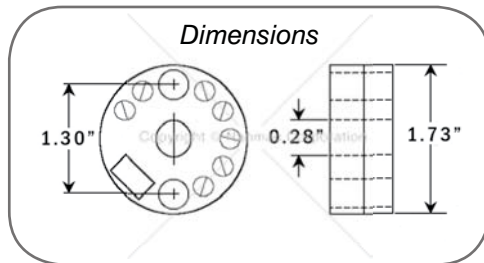

### NOTES:

- Accepts RTD in three and four wire connection and 11 thermocouple types
- NAMUR compliant
- Easy wiring, robust terminals and large center hole
- Rugged design tested for 5g vibrations

### User Specified Information (programmed by NANMAC)

- 1) Input Sensor Type
- 2) Cold Junction (thermocouple only, default is 32°F / 0°C)
- 3) Temperature Scale °F or °C
- 4) Temperature Range (full sensor range as default)
- 5) Sensor Break Detection (upscale or downscale - upscale is default)

### Temperature Ranges and Specifications

<b>Input RTD</b> 3-,4-wire connection	Pt100 (a=0.00385)	-200 to 1000°C / -328 to 1832°F
	Pt1000 (a=0.00385)	-200 to 200°C / -328 to 392°F
	PtX10 ≤X≤ 1000 (a=0.00385)	Upper Range Depending on X-Value
	Pt100 (a=0.003902)	-200 to 1000°C / -328 to 1832°F
	Pt100 (a=0.003916)	-200 to 1000°C / -328 to 1832°F
	Ni100 (1)	-60 to 250°C / -76 to 482°F
Ni1000 (1)	-10 to 150°C / 14 to 302°F	
<b>Input Thermocouples</b>	Types:	B, C, E, J, K, N, R, S, T
<b>Sensor Failure</b>	Upscale, Downscale or Off	
<b>Adjustments - Zero</b>	Any Value Within Range Limits	
<b>Minimum Spans</b>	100° either F or C	
<b>Output</b>	4-20 Temperature Linear	
<b>Operating Temperature</b>	-40 to 85°C / -40 to 185°F	
<b>Galvanic Isolation</b>	No	
<b>Power Supply</b>	8 to 36 VDC	
<b>Typical Accuracy</b>	±0.15% of Temperature Span	
<b>Connection Head</b>	DIN B or Larger	

11 Mayhew Street  
Framingham, MA 01702  
www.Nanmac.com  
engineering@nanmac.com

Foremost in Temperature Measurement™  
**NANMAC**

US & Canada: 1.800.786.4669  
International: 1.508.872.4811  
Fax: 1.508.879.5450  
info@nanmac.com