

# PRODUCT INFO SHEET

Nanmac Corporation

Quality • Performance • Solutions

## Economical Pipe-Line Thermocouple & RTD Simple Installation Into Pipelines D7 Series

### NOTES:

- Conventional thermocouple with stainless steel sheaths and grounded junctions
- Available in thermocouple calibration types: E, J, K, N & T
- Also available with Pt100 ohm RTD
- Temperature range to 500 degrees Fahrenheit
- Pressure range to 500 psi
- Sensing junction immersed 1/3 diameter into stream

### Stainless Steel Union

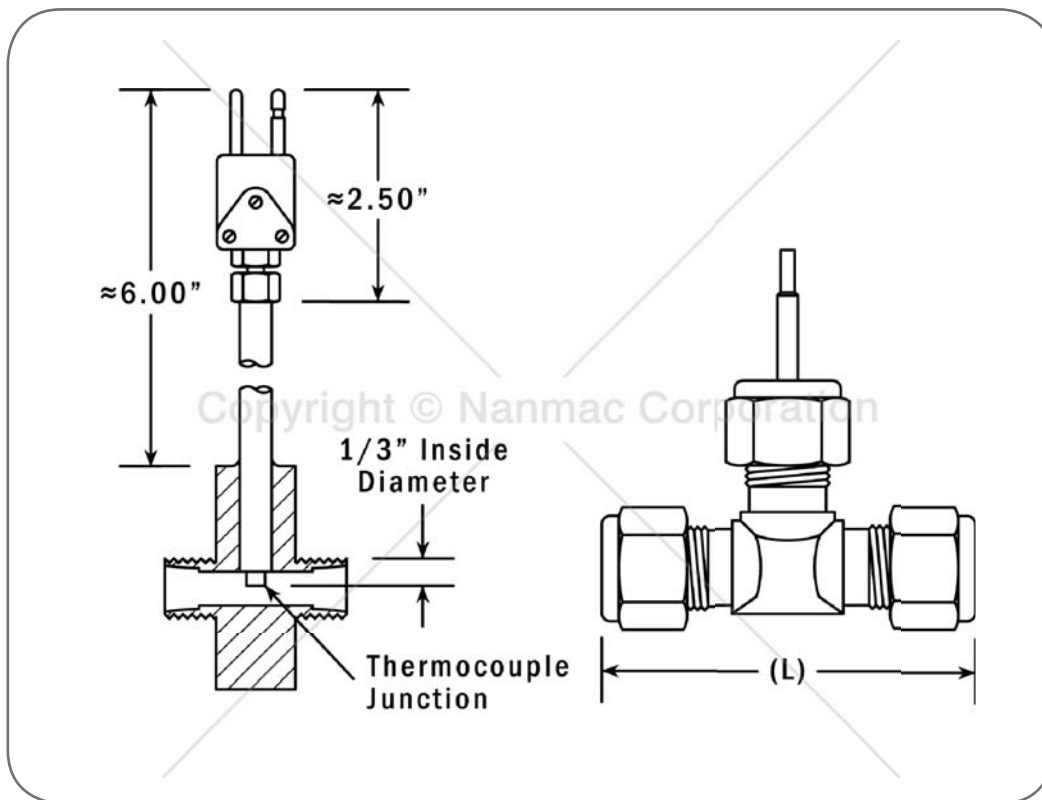

### Specifications

Part No.	Tube OD (D)	Hex (H)	Length (L)
D7-4T-(•)-(*)	1/4	9/16	2.12
D7-5T-(•)-(*)	5/16	5/8	2.34
D7-6T-(•)-(*)	3/8	11/16	2.40
D7-8T-(•)-(*)	1/2	7/8	2.84
D7-10T-(•)-(*)	5/8	1.0	3.06
D7-12T-(•)-(*)	3/4	1-1/8	3.14
D7-16T-(•)-(*)	1.0	1-1/2	3.86

11 Mayhew Street  
Framingham, MA 01702  
www.Nanmac.com  
engineering@nanmac.com

Foremost in Temperature Measurement™  
**NANMAC**

US & Canada: 1.800.786.4669  
International: 1.508.872.4811  
Fax: 1.508.879.5450  
info@nanmac.com