

# PRODUCT INFO SHEET

Nanmac Corporation

Quality • Performance • Solutions

## Heavy Duty Tapered Thermowells with Lagging Extension for 1/4" & 3/8" Diameter Elements A26A Series

### NOTES:

- Stainless steel or brass compression fittings are available for mounting probes into these thermowells.

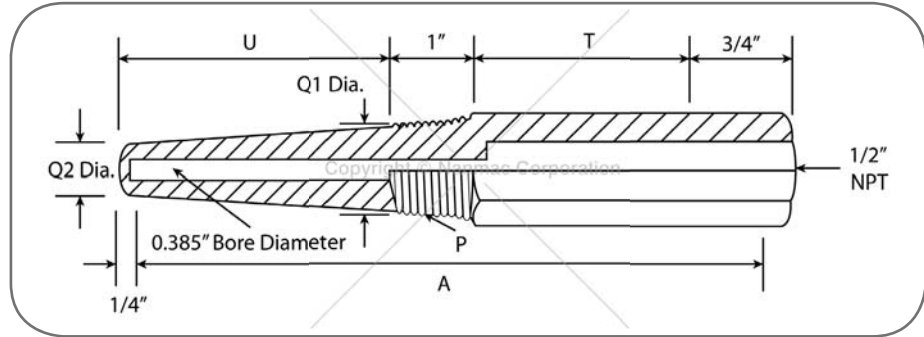

1/4" Diameter Probe - Temperature Rating - PSI							
Material	Temperature °F						
	70°F	200°F	400°F	600°F	800°F	1,000°F	1,200°F
Brass	5,300	4,750	1,100	-	-	-	-
Carbon Steel	5,950	5,750	5,450	5,250	4,000	1,750	-
SS 304	7,800	7,050	6,400	6,150	6,000	5,190	1,875
SS 316	7,800	7,800	7,250	7,100	6,950	5,800	2,720
Monel	7,450	6,850	6,150	6,100	5,940	1,750	-

3/8" Diameter Probe - Temperature Rating - PSI							
Material	Temperature °F						
	70°F	200°F	400°F	600°F	800°F	1,000°F	1,200°F
Brass	5,000	4,200	1,000	-	-	-	-
Carbon Steel	5,200	5,000	5,800	4,600	3,500	1,500	-
SS 304	7,000	6,200	5,600	5,400	5,200	4,500	1,675
SS 316	7,000	7,000	6,400	6,200	6,100	5,100	2,500
Monel	6,500	6,000	5,400	5,360	5,200	1,500	-

### Specifications

Lagging Extension (T)	Exterior Thread (P)	Stem Length (A)	Insertion Length (U)	Shank Diameter (Q)	Bore Diameter (B) = ~0.260" Shank Diameter Q1-7/8" Q2-5/8"			
					Material SS304	Material SS316	Material Brass	Material Carbon Steel
					Part No.	Part No.	Part No.	Part No.
2	3/4" NPT	6	2-1/2	3/4"	A26A-1	A26A-13	A26A-37	A26A-49
3		9	4-1/2		A26A-2	A26A-14	A26A-38	A26A-50
3		12	7-1/2		A26A-3	A26A-15	A26A-39	A26A-51
3		15	10-1/2		A26A-4	A26A-16	A26A-40	A26A-52
3		18	13-1/2		A26A-5	A26A-17	A26A-41	A26A-53
3		24	19-1/2		A26A-6	A26A-18	A26A-42	A26A-54
2	1" NPT	6	2-1/2	7/8"	A26A-7	A26A-19	A26A-43	A26A-55
3		9	4-1/2		A26A-8	A26A-20	A26A-44	A26A-56
3		12	7-1/2		A26A-9	A26A-21	A26A-45	A26A-57
3		15	10-1/2		A26A-10	A26A-22	A26A-46	A26A-58
3		18	13-1/2		A26A-11	A26A-23	A26A-47	A26A-59
3		24	19-1/2		A26A-12	A26A-24	A26A-48	A26A-60
					Bore Diameter (B) = 0.385" Shank Diameter Q1-1-1/16" Q2-49/64"			
2	1" NPT	6	2-1/2	7/8"	A26A-25	A26A-31	A26A-61	A26A-67
3		9	4-1/2		A26A-26	A26A-32	A26A-62	A26A-68
3		12	7-1/2		A26A-27	A26A-33	A26A-63	A26A-69
3		15	10-1/2		A26A-28	A26A-34	A26A-64	A26A-70
3		18	13-1/2		A26A-29	A26A-35	A26A-65	A26A-71
3		24	19-1/2		A26A-30	A26A-36	A26A-66	A26A-72

11 Mayhew Street  
Framingham, MA 01702  
www.Nanmac.com  
engineering@nanmac.com

Foremost in Temperature Measurement™  
**NANMAC**

US & Canada: 1.800.786.4669  
International: 1.508.872.4811  
Fax: 1.508.879.5450  
info@nanmac.com

3/8" Diameter Probe Specifications							
Material	Temperature °F						
	70°F	200°F	400°F	600°F	800°F	1,000°F	1,200°F
Brass	5,000	4,200	1,000	-	-	-	-
Carbon Steel	5,200	5,000	5,800	4,600	3,500	1,500	-
SS 304	7,000	6,200	5,600	5,400	5,200	4,500	1,675
SS 316	7,000	7,000	6,400	6,200	6,100	5,100	2,500
Monel	6,500	6,000	5,400	5,360	5,200	1,500	-

Stainless Steel Unit Specifications							
Lagging Extension (T)	Exterior Thread (P)	Element Length (A)	Insert Length (U)	Bore Diameter (B) 0.260" Shank Diameter Q1-7/8" Q2-5/8"		Bore Diameter (B) 0.385" Shank Diameter Q1-1-1/16" Q2-49/64"	
				SS 304	SS 316	SS 304	SS 316
				Part No.	Part No.	Part No.	Part No.
2	3/4" NPT	6	2-1/2	A26A-1	A26A-13	N/A	N/A
3		9	4-1/2	A26A-2	A26A-14		
3		12	7-1/2	A26A-3	A26A-15		
3		15	10-1/2	A26A-4	A26A-16		
3		18	13-1/2	A26A-5	A26A-17		
3		24	19-1/2	A26A-6	A26A-18		
2	1" NPT	6	2-1/2	A26A-7	A26A-19	A26A-25	A26A-31
3		9	4-1/2	A26A-8	A26A-20	A26A-26	A26A-32
3		12	7-1/2	A26A-9	A26A-21	A26A-27	A26A-33
3		15	10-1/2	A26A-10	A26A-22	A26A-28	A26A-34
3		18	13-1/2	A26A-11	A26A-23	A26A-29	A26A-35
3		24	19-1/2	A26A-12	A26A-24	A26A-30	A26A-36

Carbon Steel & Brass Unit Specifications							
Lagging Extension (T)	Exterior Thread (P)	Element Length (A)	Insert Length (U)	Bore Diameter (B) 0.260" Shank Diameter Q1-7/8" Q2-5/8"		Bore Diameter (B) 0.385" Shank Diameter Q1-1-1/16" Q2-49/64"	
				Brass	Carbon Steel	Brass	Carbon Steel
				Part No.	Part No.	Part No.	Part No.
2	3/4" NPT	6	2-1/2	A26A-37	A26A-49	N/A	N/A
3		9	4-1/2	A26A-38	A26A-50		
3		12	7-1/2	A26A-39	A26A-51		
3		15	10-1/2	A26A-40	A26A-52		
3		18	13-1/2	A26A-41	A26A-53		
3		24	19-1/2	A26A-42	A26A-54		
2	1" NPT	6	2-1/2	A26A-43	A26A-55	A26A-61	A26A-67
3		9	4-1/2	A26A-44	A26A-56	A26A-62	A26A-68
3		12	7-1/2	A26A-45	A26A-57	A26A-63	A26A-69
3		15	10-1/2	A26A-46	A26A-58	A26A-64	A26A-70
3		18	13-1/2	A26A-47	A26A-59	A26A-65	A26A-71
3		24	19-1/2	A26A-48	A26A-60	A26A-66	A26A-72